



HENRY PARK PRIMARY SCHOOL
2025 TERM REVIEW 2
MATHEMATICS
PRIMARY 6

Paper 2 : _____ / 55

Name: _____ ()

Class: Primary 6 _____

Date: _____

Paper 2

Questions 1 to 5 carry 2 marks each. Show your working clearly and write your answers in the spaces provided. For questions which require units, give your answers in the units stated.

(10 marks)

1. Onions are sold at 25¢ per 100 g at a supermarket. What is the price of 3.6 kg of onions?

Ans: \$ _____

2. Siti had a bottle of honey. She used an equal amount of honey each day. At the end of the 6th day, $\frac{2}{3}$ of the honey was left. At the end of the 8th day, 400 ml of honey was left. What was the amount of honey in the bottle at first?

Ans: _____ ml

3. The diagram shows a rectangle containing two identical quarter circles, each with a radius of 37 cm. The rectangle has a perimeter of 236 cm. What is the perimeter of the unshaded part? Give your answer correct to 2 decimal places.

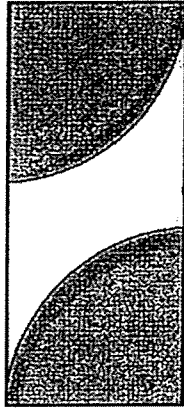

Ans: _____ cm

4. At first, Kathy had a total of 78 yellow and red balloons. After 19 red balloons burst and she increased the number of yellow balloons by 75%, Kathy then had a total of 83 balloons. How many red balloons did Kathy have at first?

Ans: _____

5. The pie chart represents the sports played by some Primary 6 students. Each student played only one sport. The number of students who played each sport is shown in the table.

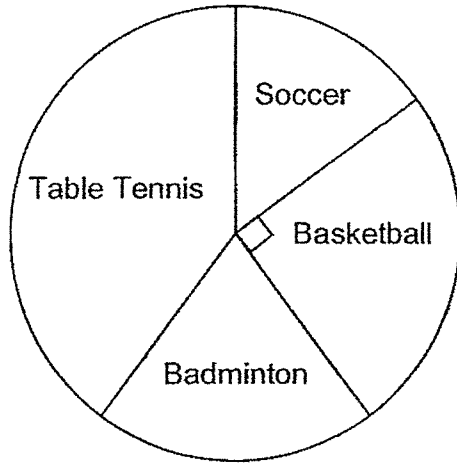

Sport	Number of Students
Soccer	?
Basketball	47
Badminton	38
Table Tennis	75

How many students played soccer?

Ans: _____

For questions 6 to 17, show your working clearly and write your answers in the spaces provided. The number of marks available is shown in the brackets [] at the end of each question or part-question.

(45 marks)

6. Jacob earned \$240 from selling a carton of 12 bottles of vitamins. He sold 36 000 bottles of vitamins in total.

(a) How many cartons of vitamins did he sell?

Ans: (a) _____ [1]

(b) How much did he earn from selling all the bottles of vitamins?

Ans: (b) _____ [2]

7. ABCD is a rhombus and DEFG is a square. Find $\angle FHD$.

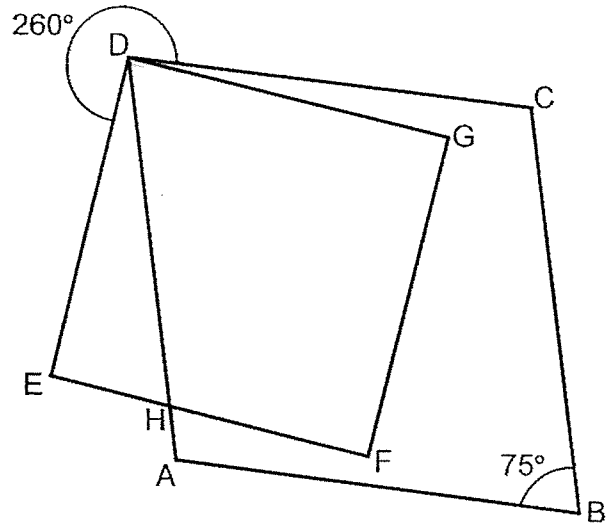

Ans: _____ [3]

8. 5 identical tables cost as much as 7 identical chairs. Each table cost \$54 more than the chair. Find the total cost of the 5 tables and 7 chairs.

Ans: _____ [3]

9. A hawker had some eggs. He used $\frac{1}{3}$ of them on Saturday and $\frac{7}{12}$ of the rest on Sunday. After that, he bought 104 eggs and then had as many eggs as he had at first. How many eggs did he have at first?

Ans: _____ [4]

10. Eagle Express Delivery Company charges \$3.50 for parcels delivered on time and \$1.80 for parcels delivered late. In May, the company could earn \$382.50 more had all the parcels been delivered on time.

(a) How many parcels were delivered late in May?

Ans: (a) _____ [2]

(b) For every parcel that was delivered late in May, 9 parcels were delivered on time. How much did the company earn in May?

Ans: (b) _____ [2]

11. Jacinta had two identical bottles each completely filled with mixtures of oil and water. The capacity of each bottle is 600 ml. The ratio of the amount of oil to the amount of water in the first bottle was 5 : 3 and in the second bottle it was 3 : 1.

(a) Jacinta emptied both bottles into an empty pail. What was the ratio of the amount of oil to the amount of water in the pail?

Ans: (a) _____ [2]

(b) After Jacinta poured more water into the pail, the amount of oil and water in the pail was in the ratio of 2 : 1. How much water did Jacinta pour into the pail?

Ans: (b) _____ [3]

12. 25% of Lina's money was spent on 5 files and 10 erasers. The cost of each file was 4 times the cost of each eraser. Lina bought more files with 40% of her remaining money. How many files did she buy altogether?

Ans: _____ [3]

13. The figure below is made up of a square, a quarter circle and a semicircle. The area of the square is 196 cm^2 . Find the total area of the shaded parts.

(Take $\pi = \frac{22}{7}$)

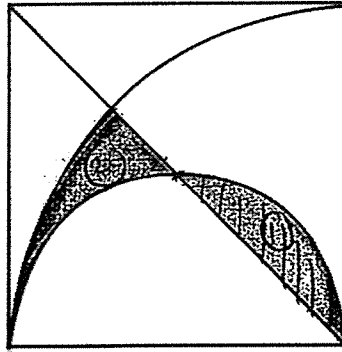

Ans: _____ [3]

14. At the start of a party, there were 70 children. Each boy was given 5 candies and each girl was given 3 candies. A total of 260 candies were given out.

(a) Find the number of boys at the party.

Ans: (a) _____ [2]

(b) Halfway through the party, 3 boys and some girls joined in. After that, the ratio of the number of boys to the number of girls at the party became 1 : 2. Find the number of girls who joined the party later.

Ans: (b) _____ [2]

15. The pie chart below shows the number of \$10, \$20, \$50 and \$100 concert tickets sold by an event organiser.

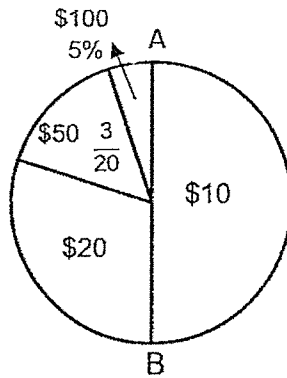

- (a) AB is a straight line. What fraction of the tickets sold were \$20 tickets?

Ans: (a) _____ [1]

- (b) The organiser sold 160 more \$50-tickets than \$100-tickets, how many \$10-tickets were sold?

_____ [2]

16. In the figure, ABC is a triangle, BGF and ADJ are 2 identical quarter circles, CDEF and EGHJ are squares. The area of square CDEF is 25 cm^2 and the radius of the quarter circles is 18 cm . Find the total area of the unshaded parts of the figure.
(Take $\pi = 3.14$)

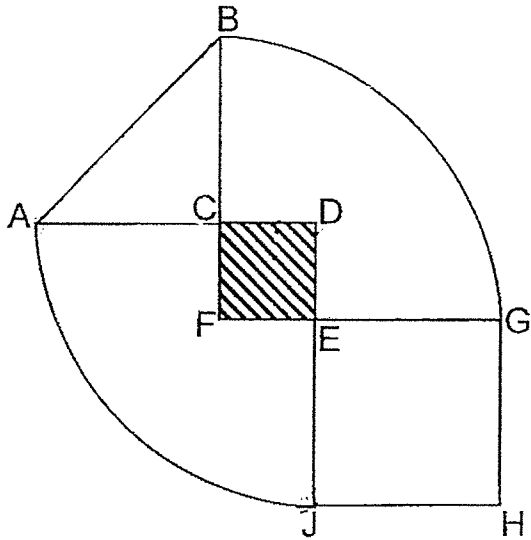

Ans: _____ [5]

17. The figures below show trapezium ABCD and equilateral triangle EFG. The trapezium was folded along line DH to form a parallelogram, HBCD. Triangle EFG was then pasted over parallelogram HBCD such that points E and B meet as shown. Line DF is a straight line.

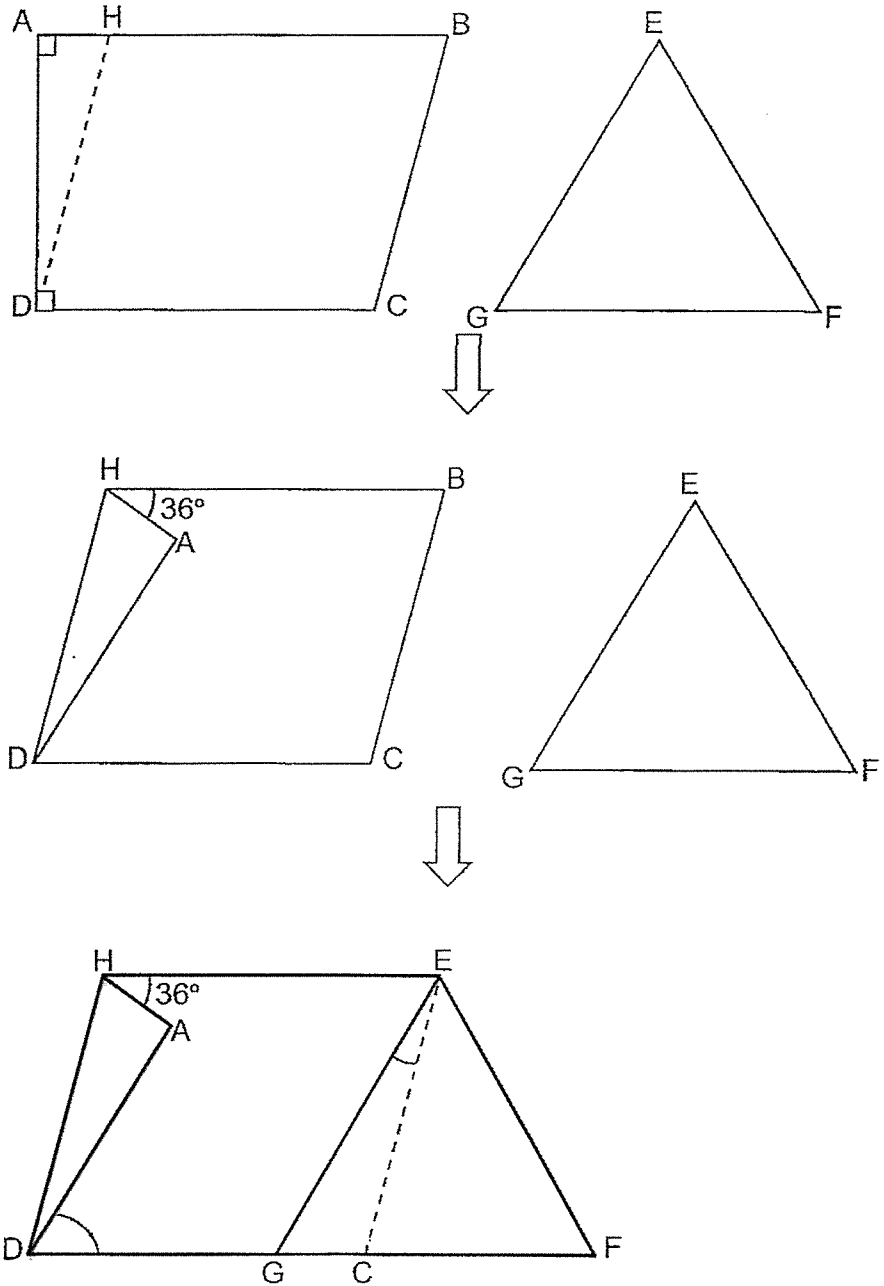

17. (a) Find $\angle ADG$.

Ans: (a) _____ [3]

(b) Find $\angle CEG$.

Ans: (b) _____ [2]

YEAR : 2025
 LEVEL : PRIMARY 6
 SCHOOL : HENRY PARK PRIMARY SCHOOL
 SUBJECT : MATHEMATICS
 TERM : TERM REVIEW 2

Q1	$3.6\text{kg} = 3600\text{g}$ $3600\text{g} \div 100\text{g} = 36$ $\$0.25 \times 36 = \9	Q2	$\frac{2}{3} = \frac{12}{18}$ $\frac{3}{8} = \frac{6}{16}$ $\frac{1}{3} = \frac{6}{18}$ $12 - 2 = 10$ $400 \div 10 = 40$ $18 \times 40 = 720\text{ml}$
Q3	$\frac{1}{4} \times \pi \times 74 \times 2 = 37\pi$ $88 + 37\pi \approx 204.24\text{cm}$	Q4	$85 + 19 = 102$ $102 - 78 = 24$ $75u = 24$ $25u = 24 \div 3 = 8$ $100u = 8 \times 4 = 32$ $59 - 32 = 27$ $27 + 19 = 46$
Q5	$\text{Total} = 47 \times 4 = 188$ $S = 188 - 47 - 38 - 75 = 28$	Q6	(a) $12 \text{ bottles} = \$240$ $36000 \text{ bottles} = 36000 \div 12$ $= 3000 \text{ cartons}$ (b) $3000 \times \$240 = \720000
Q7	$360 - 75 - 260 = 25^\circ$ $180 - 90 - 25^\circ = 65^\circ$ $180 - 65 = 115^\circ$	Q8	$5 \times \$54 = \270 $2C = \$270$ $1C = \$270 \div 2 = \135 $7C = \$135 \times 7 = \945 $\$945 \times 2 = \1890
Q9	$5u + 104 = \text{Original}$ $18u - 5u = 13u$ $13u = 104$ $1u = 104 \div 13 = 8$ $18u = 8 \times 13 = 144$	Q10	(a) $\$3.50 - \$1.80 = \$1.70$ $\$382.50 \div \$1.70 = 225$ (b) $225 \times 9 = 2025$ $2025 \times \$3.50 = \7087.50 $225 \times \$1.80 = \405 $\$7087.50 + \$405 = \$7492.50$
Q11	(a) O : W $5 : 3$ (Total = 8u) O : W $3 : 1$ (Total 4) $6 : 2$ (Total 8) O : W $5 + 6 : 3 + 2$ $= 11 : 5$	Q12	$4u \times 5 + 10E$ $= 4u \times 5 + 10u$ $= 30u$ $1F = 4u$ $1E = 1u$ $18 \times 2 = 36u$ $(36 \div 4) + 5$ $= 14$

