

**Red Swastika School
Primary 6 Science 2025
Class Test 2**

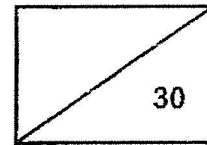

Name: _____ () Parent's Signature: _____

Class: _____ Date: _____

Total time: 45 minutes

Section A: Multiple – Choice Questions (9 x 2 = 18 marks)

Choose the most suitable answer and shade its number in the OAS provided.

1. The diagram below shows the presence of some traits in Caleb's family tree.

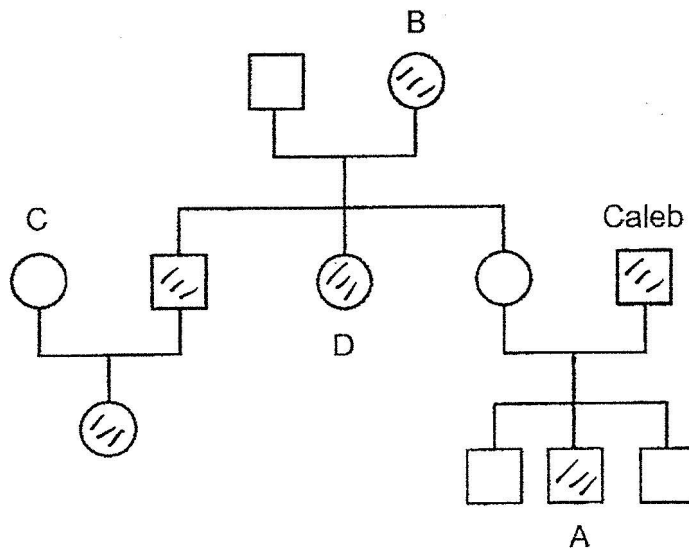

Key:	
	female with curly hair
	male with curly hair
	female with straight hair
	male with straight hair

Which of the following statements is true of the above family tree?

- (1) D did not inherit curly hair.
- (2) C inherited curly hair from B.
- (3) Caleb passed on curly hair to A.
- (4) Curly hair can only be inherited by males in the family.

2. Ariana conducted an experiment on substances E and F using the set-up as shown below, at room temperature of 30°C .

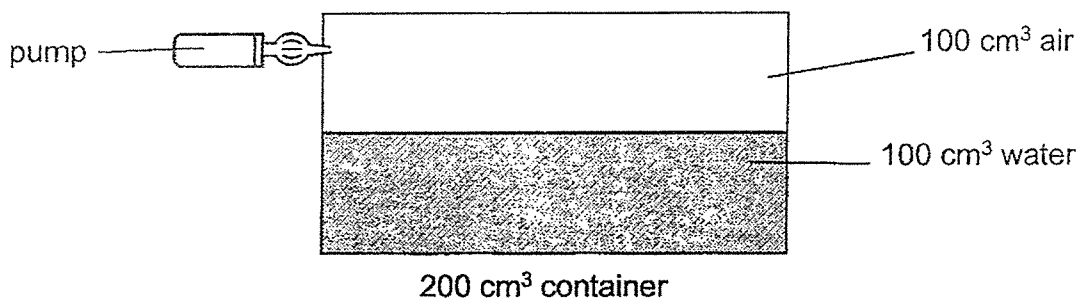

The table below shows the freezing and boiling points of substances E and F.

Substance	Freezing point ($^{\circ}\text{C}$)	Boiling point ($^{\circ}\text{C}$)
E	5	24
F	20	40

He used the pump to pump in 50 cm^3 of substance E and 50 cm^3 of substance F. What is the final volume of gas in the container?

- (1) 50 cm^3
- (2) 100 cm^3
- (3) 150 cm^3
- (4) 300 cm^3

3. Study the diagram carefully.

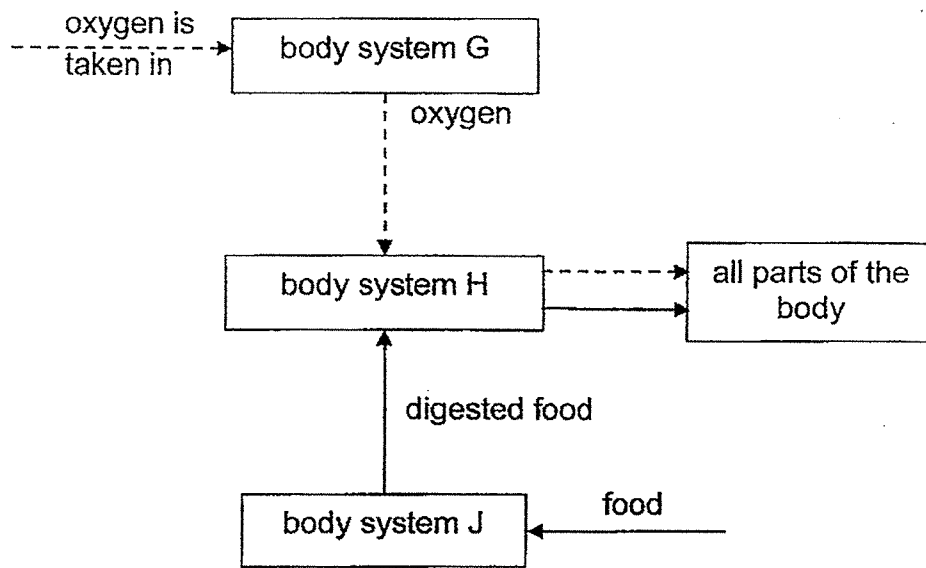

Key

Direction of food \longrightarrow

Direction of oxygen $- - - \longrightarrow$

Based on the diagram above, which human body systems do G, H and J represent?

	body system G	body system H	body system J
(1)	respiratory	digestive	circulatory
(2)	respiratory	circulatory	digestive
(3)	circulatory	respiratory	digestive
(4)	digestive	respiratory	circulatory

4. The diagram below shows a plant growing in the school garden.

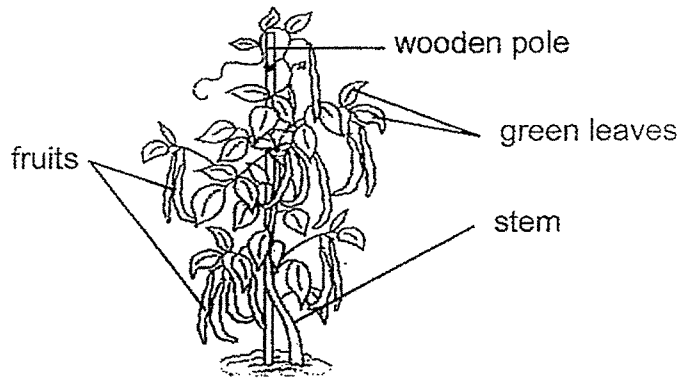

Which of the following statement(s) is/are correct?

- A The plant can make food.
- B It is a non-flowering plant.
- C The plant has a weak stem.

- (1) A and B only
- (2) A and C only
- (3) B and C only
- (4) All of the above

5. Study the leaf cell shown below.

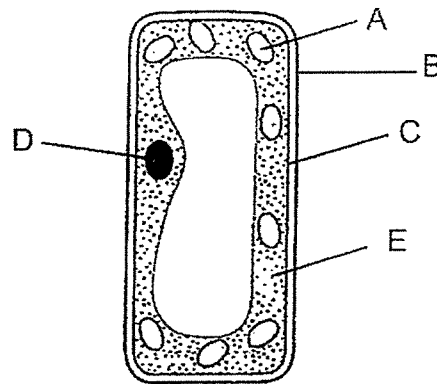

Which parts are found in a root hair cell and cheek cell?

	root hair cell	cheek cell
(1)	A, B, C	A, B, C, E
(2)	B, C, E	A, B, E
(3)	A, C, D, E	B, C, D
(4)	B, C, D, E	C, D, E

6. Tate made a circuit tester where X and Y are the ends of two crocodile clips. He also made a circuit card where he used paper clips to label points M, N, P, Q and R. He then connected a wire to some of the points on the circuit card as shown below.

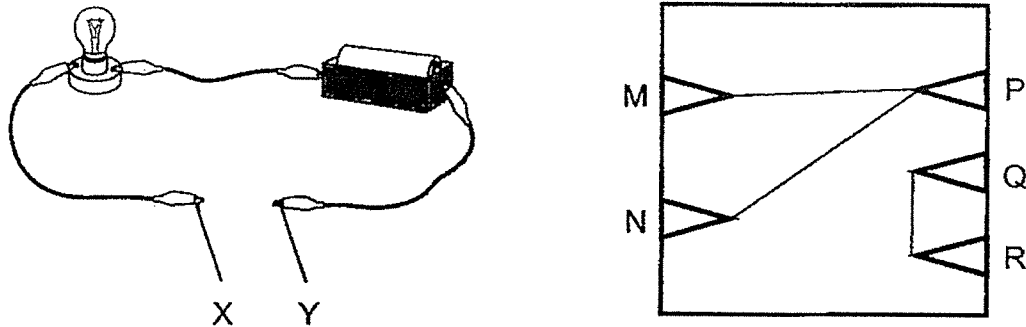

Which two points in the circuit card should be connected to points X and Y to light up the bulb?

- (1) P and Q
- (2) M and N
- (3) P and R
- (4) N and Q

7. The diagram below shows a habitat in the sea.



Which of the following statements is true?

- (1) Plant E is not an organism.
- (2) There are four populations in this habitat.
- (3) Plant E and animal D form two populations.
- (4) Animals A, B, C and D forms four communities.

8. Nora found some caterpillars eating up the vegetables in her farm. She bought some chickens and released them into the farm to control the population of the caterpillars.

She observed the change in the population of the vegetables and the caterpillars from January to December as shown below.

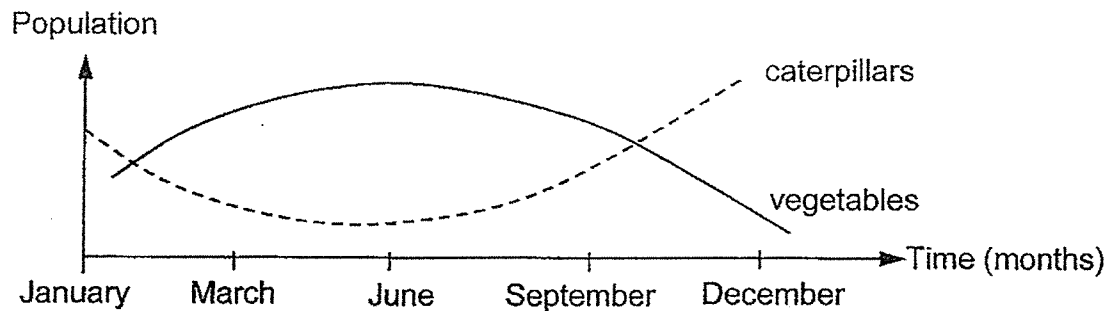

Which of the following could be the possible reason(s) for the change in population size of the caterpillars from June to December?

- A: The vegetables were infected with a disease.
 - B: The chicken population was infected with a disease.
 - C: Other plant-eating organisms were found on the farm.
 - D: Some wolves came from elsewhere to live in the forest next to the farm.
- (1) A only
(2) B only
(3) A and C only
(4) B and D only

9. The diagram below shows Shawn throwing a paper plane into the air.

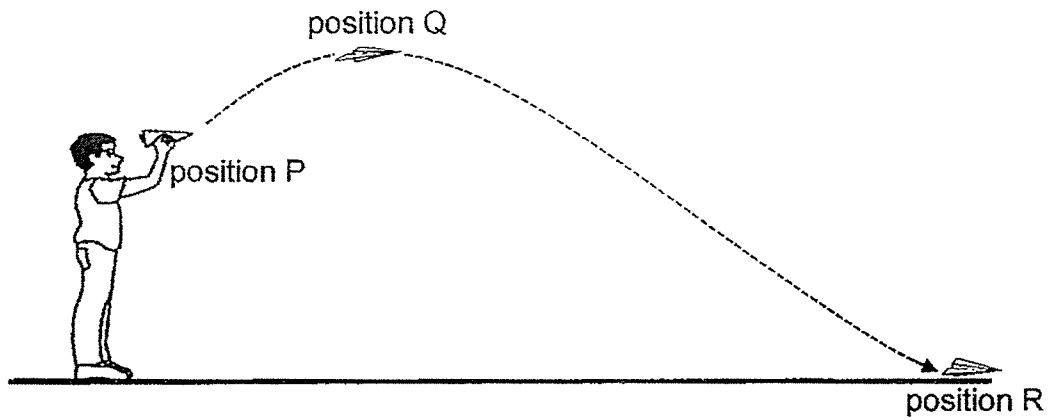

Which of the following graphs shows the correct change in the gravitational potential energy (GPE) as the paper plane moves from position P to R?

(1)

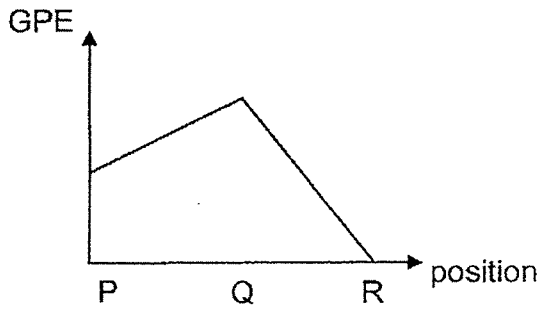

(2)

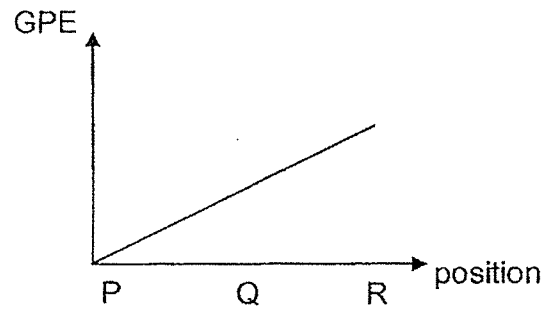

(3)

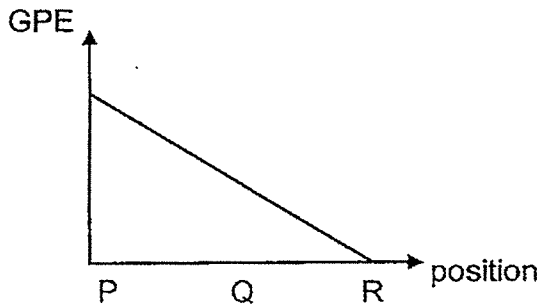

(4)

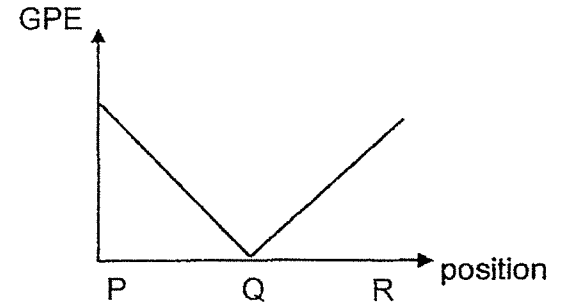

Section B: Open-Ended Questions (12 marks)

Answer all the questions in the space provided.

10. The two graphs below provide some information about a pond community.

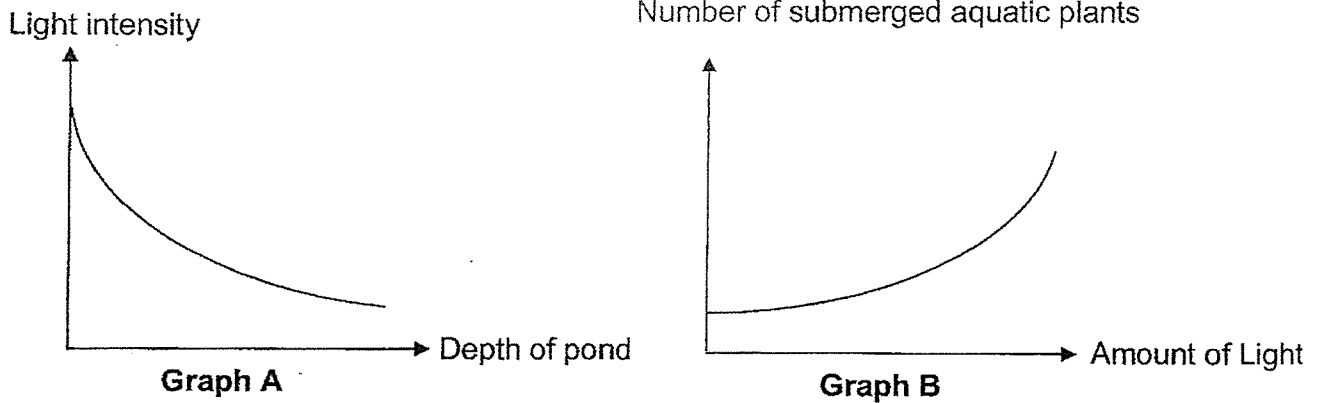

Graph A shows how light intensity changes with the depth of the pond.
Graph B shows how the number of submerged aquatic plants found changes with the amount of light in the pond.

(a) Define what is a community. (1m)

(b) Based on the graphs above, what is the relationship between the depth of the pond and the number of aquatic plants found? Explain your answer. (2m)

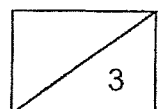

- 11 Derion carried out an experiment using some water snails and hydrilla plants. Each container contained the same volume of water and the same amount of dissolved carbon dioxide. A stopper was placed at the opening of each container.

Set-ups J and K were left under the sun while Set-ups L and M were placed in a black box for 2 hours.

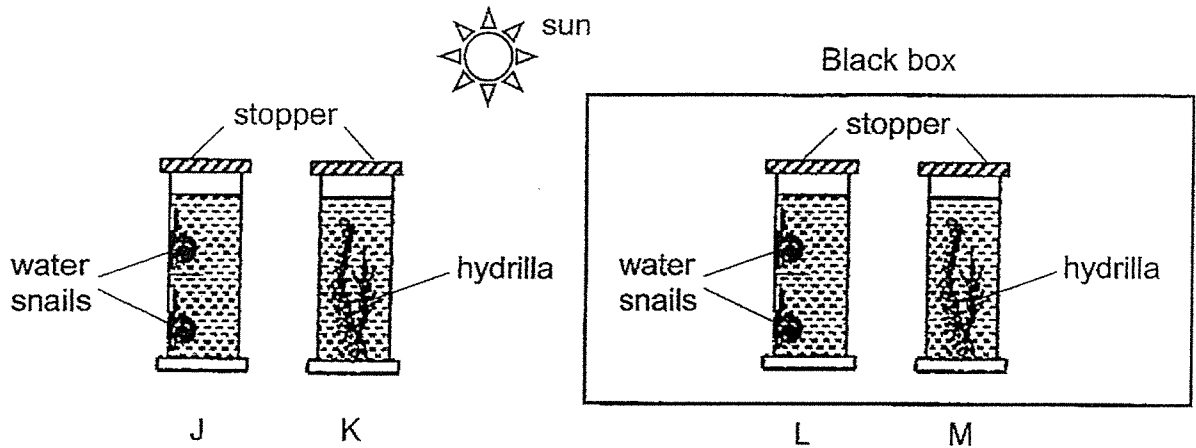

At the end of the experiment, Derion measured the amount of carbon dioxide in each set-up again. He found that there was more carbon dioxide in Set-up J than Set-up K.

- (a) Explain the difference in the amount of carbon dioxide for J and K. (1m)

- (b) Derion's friend, Carissa, commented that the amount of carbon dioxide at the end of the experiment in Set-up K is the same as that in Set-up M. Was Carissa correct? Explain your answer. (2m)

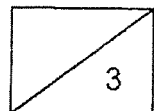

12. Kingsley tried to flip his empty bottle so that it could land on the table standing upright in Position S. He held the bottle at Position Q and then swung it upwards and forward before releasing it.

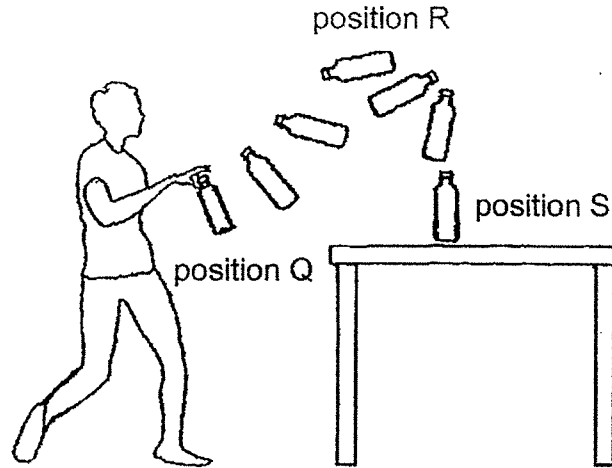

- (a) State the energy conversion of the bottle as it moved from Position Q to S. (1m)

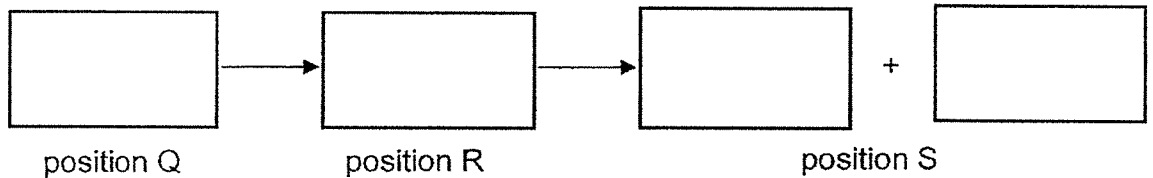

- (b) Kingsley repeats the action with a fully filled bottle. Will the maximum height of position R be higher, lower or the same, assuming he uses the same amount of force to swing the bottle at Q? (1m)

- (c) Using energy conversion, explain your answer for part (b). (2m)

End of paper
Please check your answers

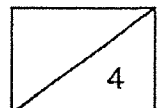

YEAR : 2025
 LEVEL : PRIMARY 6
 SCHOOL : RED SWASTIKA SCHOOL
 SUBJECT : SCIENCE
 TERM : WEIGHTED ASSESSMENT 2

class test 2

(BOOKLET A)

Q1	3	Q2	1	Q3	2	Q4	2	Q5	4
Q6	2	Q7	4	Q8	4	Q9	1		

(BOOKLET B)

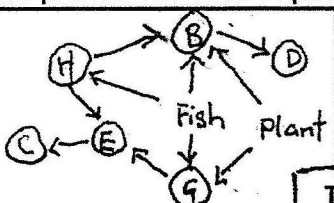
Q10	a)	A community consists of populations in a particular habitat.
	b)	As the depth of the pond increases, the number of aquatic plants found decreases. The deeper the pond, the lesser amount of light that can reach the plants. The rate of photosynthesis would thus decrease.
Q10	a)	 <p>all a. The water snails in set-up J respire and give out carbon dioxide but the hydrilla plants in set-up K will take in the carbon dioxide for photosynthesis.</p>
	b)	No. There should be a greater amount of carbon dioxide in set-up. The hydrilla plants in set-up M could not photosynthesize as there was no light, but the hydrilla plants in set-up K could take in carbon dioxide for photosynthesis in the presence of light.
Q12	a)	Kinetic energy -> Gravitational Potential Energy -> Sound energy -> Heat energy
	b)	The maximum height at position R will be lower.
	c)	When the same amount is used on a fully-filled bottle, there is less kinetic energy from Kingsley at Q. Less kinetic energy is then converted to less gravitational potential energy and kinetic energy at R. Hence maximum height is lower.

1
 END