

Henry Park Primary School  
Primary Six Science  
2025 Term Review 2

Name: \_\_\_\_\_ ( ) Class: 6 \_\_\_\_\_ Parent Signature: \_\_\_\_\_

**Booklet A (28 marks)**

For each question from 1 to 14, four options are given. One of them is the correct answer.  
Make your choice (1, 2, 3 or 4). Shade the correct oval (1, 2, 3 or 4) on the **Optical Answer Sheet**.

- 1 The diagram shows Peter's family tree.  
The members of the family are either tongue rollers or non-tongue rollers.

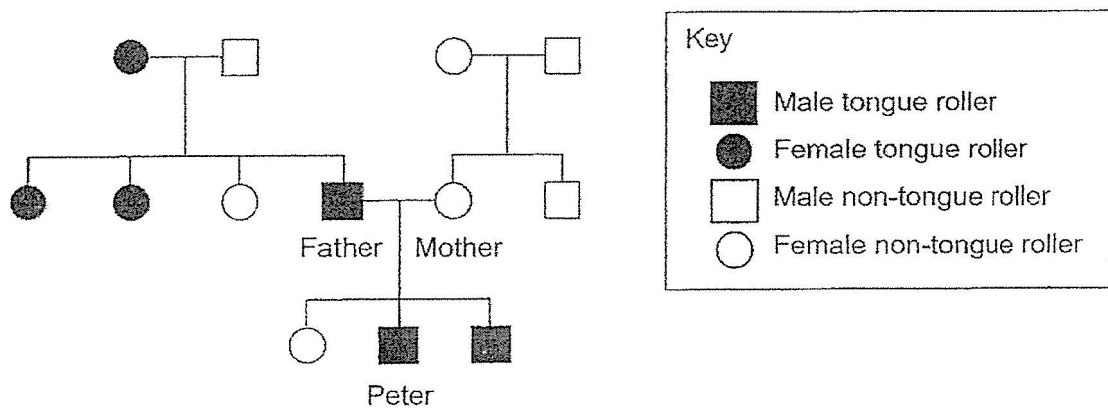

Which one of the following statements about the family tree is correct?

- (1) Peter's mother is a tongue roller.
- (2) Peter's siblings are all tongue-rollers.
- (3) One of Peter's grandparents is a tongue-roller.
- (4) Peter's mother has a sister who is a non-tongue roller.



- 2 Julia conducted an experiment to find out whether seeds need oxygen for germination.

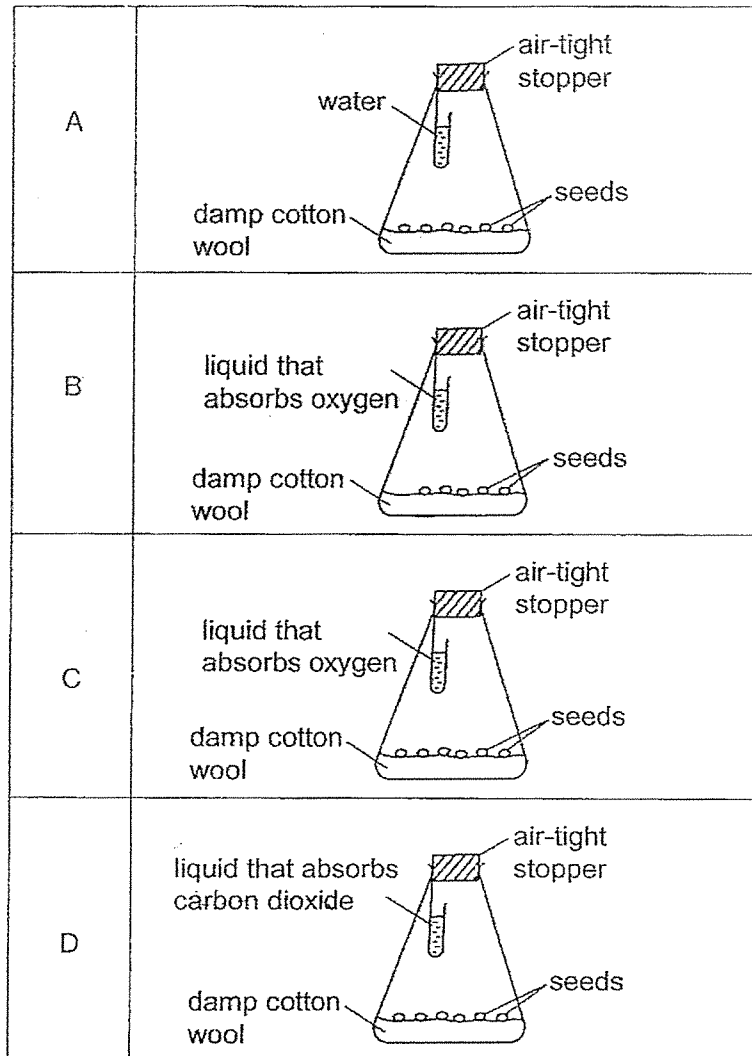

Which pair of set-ups are the most suitable for conducting a fair test?

- (1) A and B only
- (2) A and C only
- (3) A and D only
- (4) C and D only

- 3 Zhi Xing classified three different animals, P, Q and R, as shown below.

Fish	Reptiles	Birds
R	P	Q

Zhi Xing used some of the following questions to help with the classification.

Question	
E	Does it breathe through gills?
F	Is the animal's body covered with scales?
G	Does it have 6 legs?
H	Is the animal's body covered with feathers?

Which of the following questions helped him to classify animals P, Q and R?

- (1) G and H only
  - (2) E and G only
  - (3) F and H only
  - (4) E, F and H only
- 4 Which of the following about ferns and fungi are correct?

	Characteristics	Ferns	Fungi
A	Do they contain chlorophyll?	yes	no
B	Do they break down dead matter?	no	yes
C	Do they reproduce by spores?	no	yes

- (1) A and B only
- (2) B and C only
- (3) A and C only
- (4) A, B and C

5 The diagram shows the human digestive system.

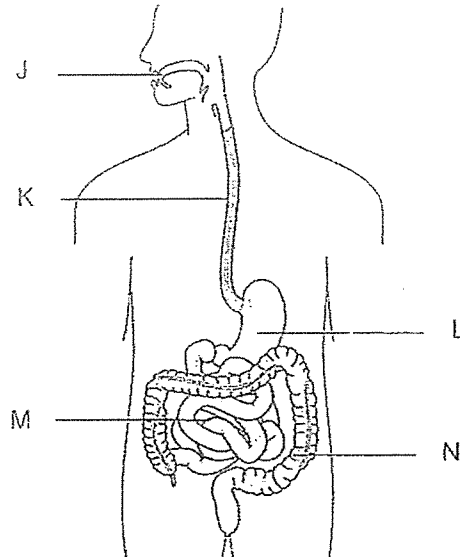

Which of the following is correct?

- (1) Digestion is completed in part N.
  - (2) Parts J, K and M do not produce digestive juices.
  - (3) Part M absorbs digested food into the bloodstream.
  - (4) Parts L and N break down food into simpler substances.
- 6 Which one of the following correctly compares the process of fertilisation in both flowering plants and humans?
- (1) Both involve the production of eggs.
  - (2) Both involve the fusion of male and female reproductive cells.
  - (3) Both involve the transfer of eggs from the male to the female.
  - (4) Both involve the development of foetus in the ovary of the female.

7 The diagram shows a fruit.

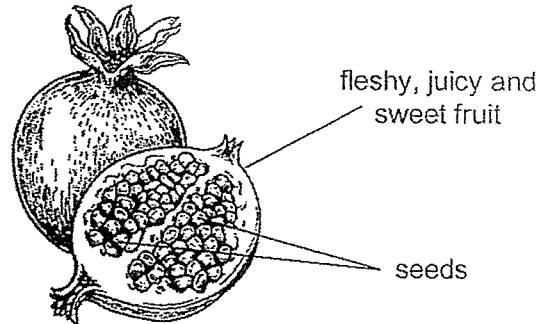

Which of the following statements are correct?

- A There were many ovules in the ovary.
- B The seeds will be dispersed by splitting.
- C Pollination and fertilisation had taken place.
- D The fruit was developed from the ovary of a flower.

- (1) A and B only
- (2) C and D only
- (3) A, C and D only
- (4) A, B, C and D

- 8 Lilian set up an experiment as shown below. She wrapped three similar leaves from the same plant in different types of plastic bags. The plastic bags were of the same size. She left the set-up under bright light for several hours.

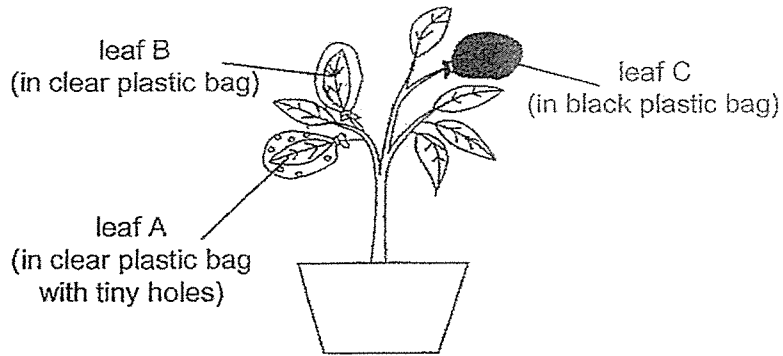

Which of the following graphs correctly represents the amount of carbon dioxide in the plastic bags after several hours?

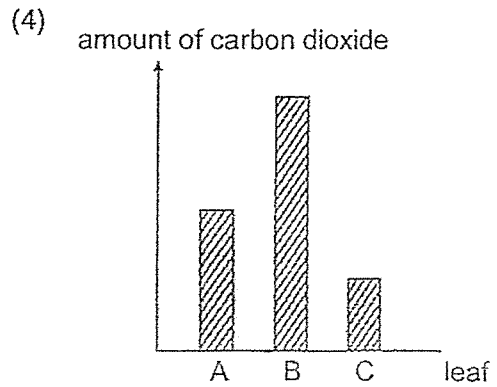
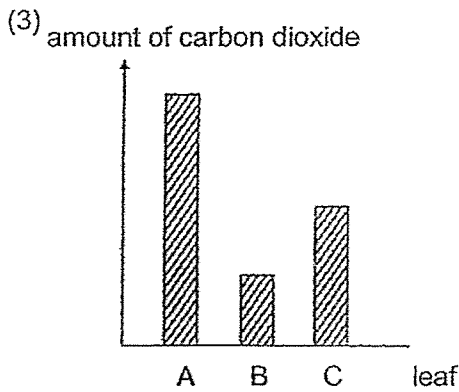
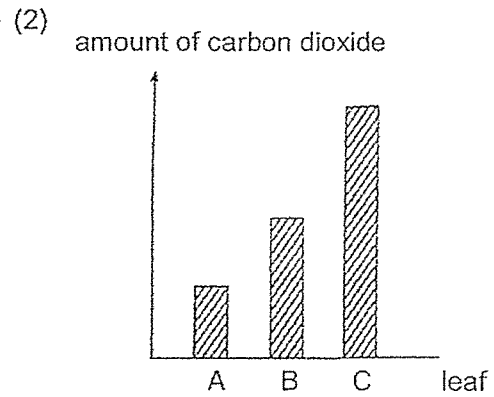
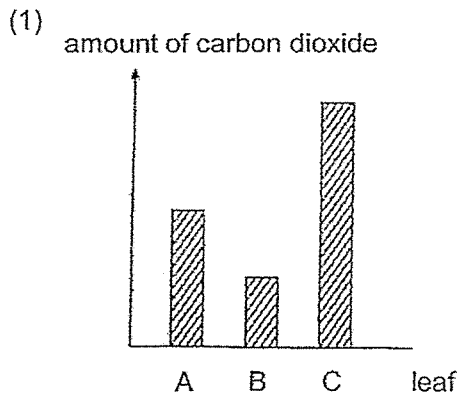

9 Devan placed the set-up shown below in a sunny place.

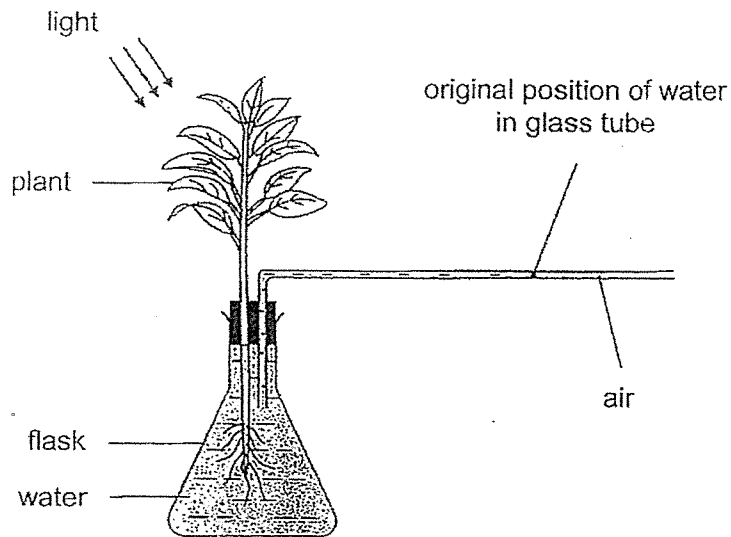

After some time, the water in the glass tube moved.

Which direction did the water move and what was the reason for the movement?

	Direction in which the water in the glass tube moved	Reason
(1)	←	water is taken in by the plant
(2)	←	carbon dioxide is taken in by the plant
(3)	→	water is given out by the plant
(4)	→	oxygen is given out by the plant

- 10 The diagram shows part of an island where three types of plants ( $\triangle$ ,  $\blacklozenge$ ,  $\bullet$ ) are growing.

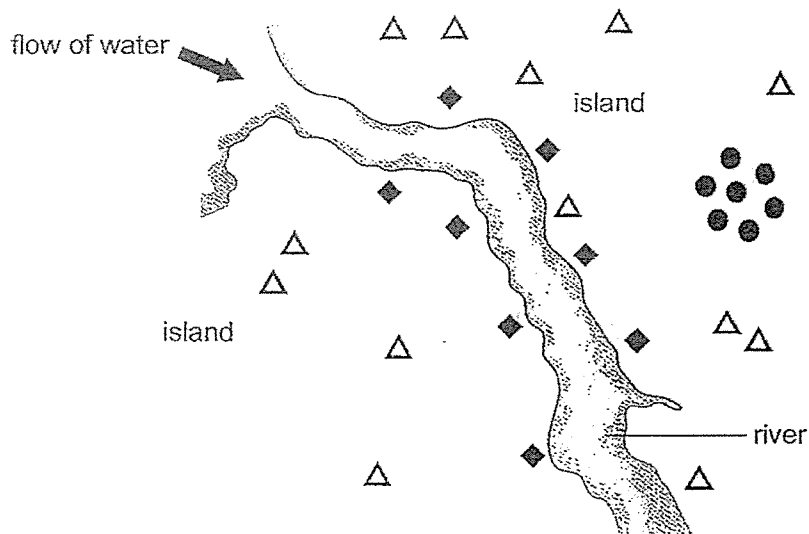

How are the fruits or seeds of each type of plant most likely to be dispersed?

	$\triangle$	$\blacklozenge$	$\bullet$
(1)	wind	water	animal
(2)	wind	animal	splitting
(3)	animal	wind	water
(4)	animal	water	splitting

- 11 The diagrams show stages in the life cycles of two insects.  
Each box represents a stage in the life cycles.

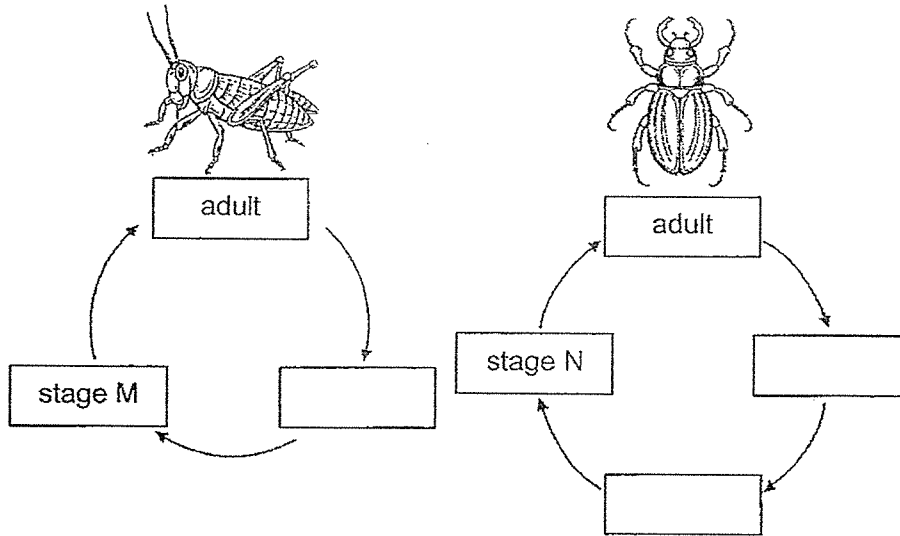

What are stages M and N?

	Stage M	Stage N
(1)	pupa	nymph
(2)	nymph	larva
(3)	nymph	pupa
(4)	larva	larva

- 12 Devi carried out an experiment on three similar slices of bread under different conditions.

Bread	Conditions
Slice A	Placed on a table in the kitchen
Slice B	Sprinkled with water and kept in the dark cupboard
Slice C	Put in an airtight container and kept in the refrigerator

She observed the three slices of bread for black spots over ten days and plotted the results in the graph shown below.

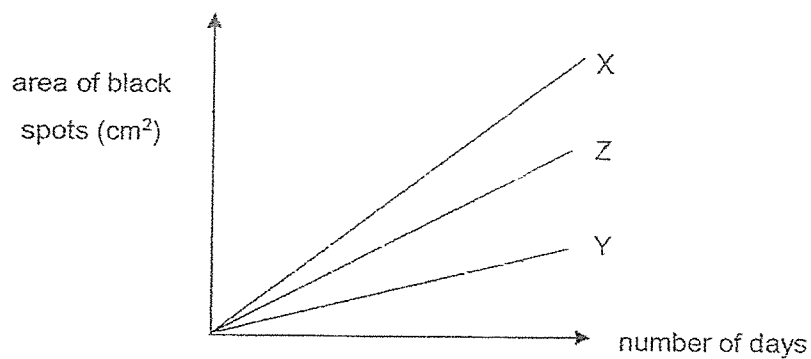

Which slices of bread best represent X, Y and Z in the graph?

	X	Y	Z
(1)	Slice A	Slice B	Slice C
(2)	Slice A	Slice C	Slice B
(3)	Slice B	Slice A	Slice C
(4)	Slice B	Slice C	Slice A

- 13 Jackie removed the outer ring of the stem from a plant between P and Q as shown. Only the food-carrying tubes were cut away with this outer ring.

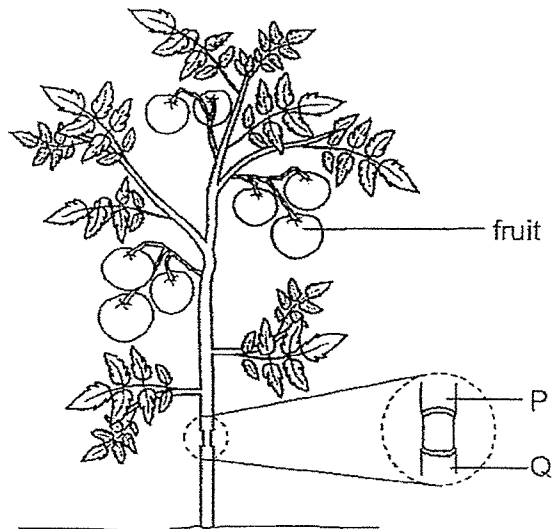

After ten days, which of the following are likely observations that Jackie could make about the plant?

- A Part Q will be swollen.
  - B Part P will be swollen.
  - C The leaves have dried up.
  - D The fruits have grown bigger.
- (1) A and B only  
(2) B and D only  
(3) B, C and D only  
(4) A, B, C and D

14 Elsa set up an experiment in a dark room as shown below.

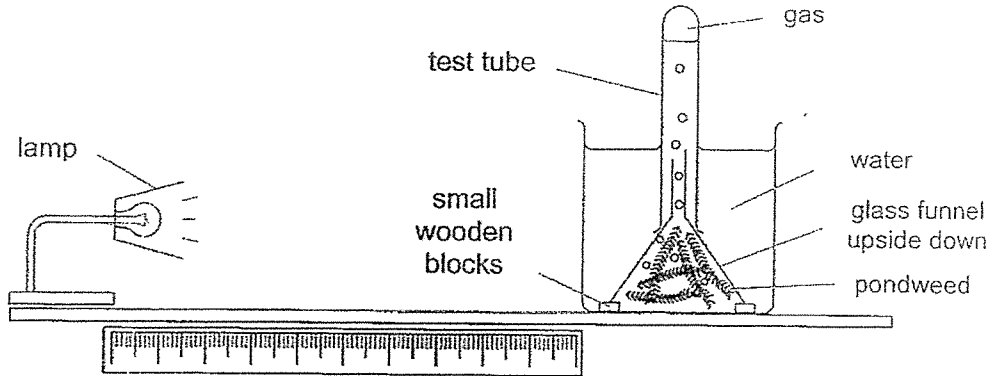

Based on the experiment, Elsa plotted the graph shown below.

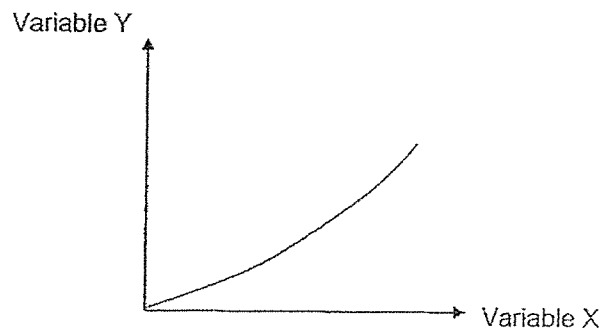

In the graph shown above, variable X is the independent variable.  
Variable Y is the dependent variable.

What are variables X and Y?

	Variable X	Variable Y
(1)	Amount of oxygen	Temperature of water in the beaker
(2)	Intensity of light	Number of bubbles produced per minute
(3)	Distance between lamp and water plant	Number of bubbles produced per minute
(4)	Number of water plants	Intensity of light

**End of Booklet A**

Henry Park Primary School  
Primary Six Science  
2025 Term Review 2

Name: \_\_\_\_\_ ( ) Class: 6 \_\_\_\_ Parent Signature: \_\_\_\_\_

Booklet B (22 marks)

For questions 15 to 20, write your answers in the space provided.

The number of marks available is shown in brackets [ ] at the end of each question or part question.

15 The diagram shows Melvin's observation of a plant cell under a microscope.

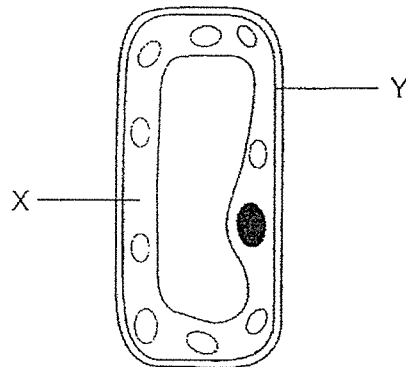

a) Name part X of the plant cell. [1]

\_\_\_\_\_

b) State the function of part Y of the plant cell. [1]

\_\_\_\_\_

\_\_\_\_\_

c) Melvin concluded that the plant cell can be found in the leaves of a plant. [2]  
Is he correct? Explain your answer.

\_\_\_\_\_

\_\_\_\_\_

\_\_\_\_\_

Question 15 continued

Single-celled organisms M and N have a cap and a nucleus at the base.

The shape of the caps are different.

A scientist took a part from each cell and joined them together as shown in diagram 1.

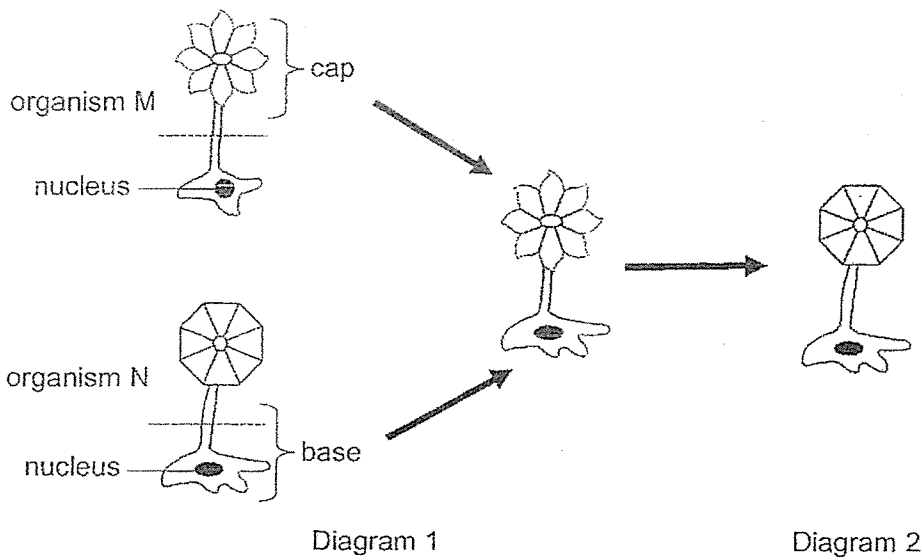

Sometime later, the shape of the cap changed as shown in diagram 2.

- d) Based on this observation, what can the scientist conclude about the function of the nucleus? [1]

---

---

- 16 Annie set up an experiment in a dark room to find out which coloured light(s) red, blue or green could be used for photosynthesis.

She divided a fish tank into 3 sections, P, Q and R, by using black plastic sheets as shown in the diagram. The coloured lights are of the same brightness.

Before adding the water plants, she noticed that the fish could be found in all three sections.

She then placed a water plant into each section. After some time, she noticed that the fish gathered in sections P and R only.

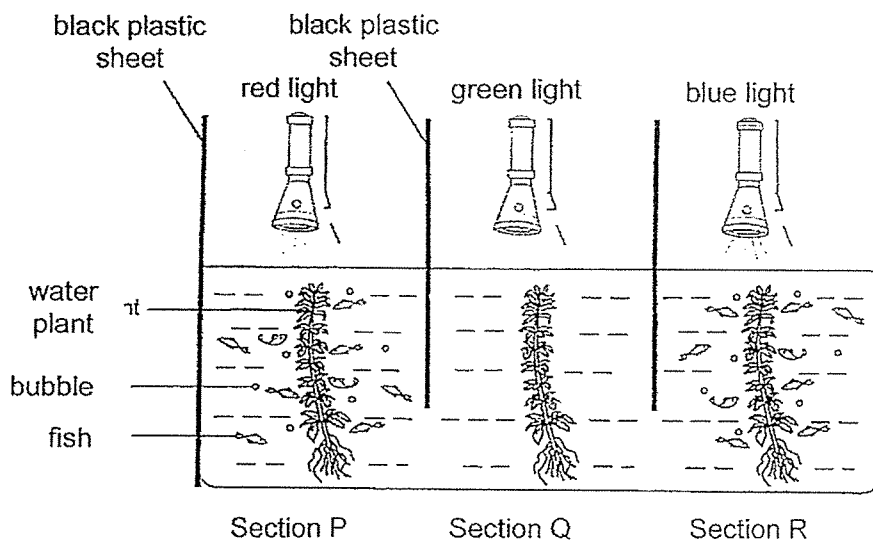

- (a) Based on Annie's experiment, which coloured light(s) could be used for photosynthesis? [1]

---

- (b) Explain your answer in part (a). [2]

---

---

---

**Question 16 continued**

Annie removed all the water plants after a day.

- (c) What would she most likely observe about the fishes in the set-up after two days? Explain your answer. [1]

---

---

- 17 P, Q, R and S are organs in the human digestive system. The graph below shows the amount of undigested food leaving each organ after a meal.

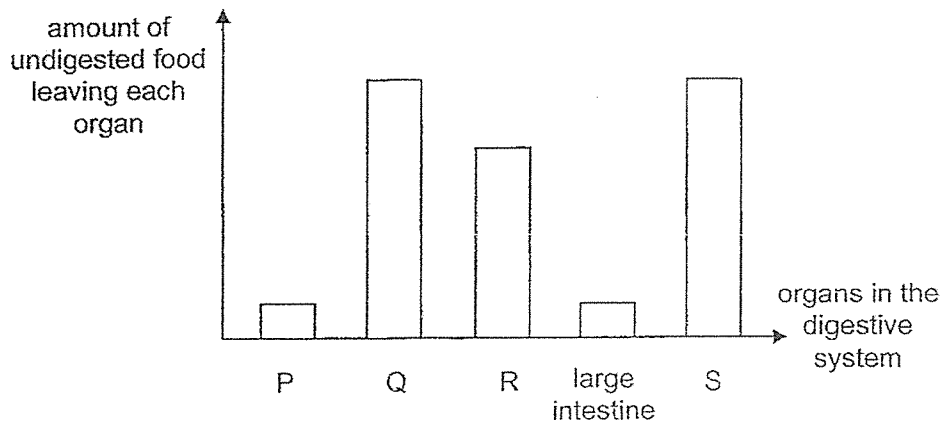

- (a) State the main function of the large intestine. [1]

---

---

- (b) State which letter, P, Q, R or S, represent the small intestine. [1]

---

- (c) Based on the graph given, explain your answer in part (b). [2]

---

- 18 The diagram shows how blood flows in certain parts of the human body. The arrows (A, B, C, D, E, F, G and H) represent the movement of blood.

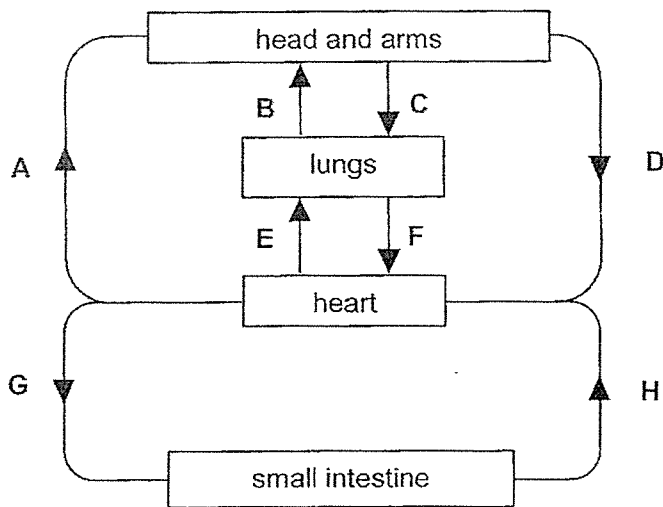

- (a) Name the human organ system to which the lungs belong. [1]

---

- (b) Which two arrows are not drawn correctly? [2]  
Explain your answer.

---



---



---

- (c) Other than the direction of blood flow, state one difference between the blood at G and the blood at H. [1]

---



---



---

- 19 Ian caught two organisms C and D from his school pond and wanted to find out whether they were animals or plants. He filled four beakers 1, 2, 3 and 4 with pond water. He placed organism C in beakers 1 and 2 and organism D in beakers 3 and 4 as shown below.

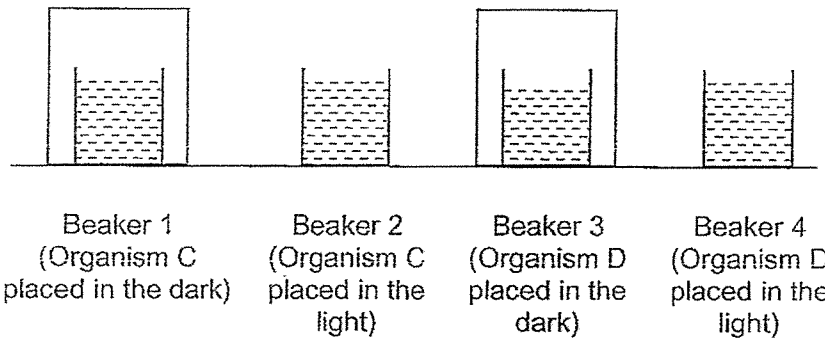

Ian added a drop of liquid A in each beaker.

The table shows the colour of liquid A in the presence of more oxygen or more carbon dioxide.

Colour of liquid A	More oxygen is present	More carbon dioxide is present
		blue

Ian recorded the colour of liquid A after the experiment as shown below.

Beaker	Colour of liquid A
1	yellow
2	yellow
3	yellow
4	blue

- (a) Based on the results, Ian concluded that organism C was an animal. Explain how he arrived at this conclusion.

[1]

Question 19 continued

- (b) Name the process that took place in beaker 4. [2]  
Explain how this process caused the change in the colour of liquid A.

---

---

---

- 20 Study the diagram of the flower below.

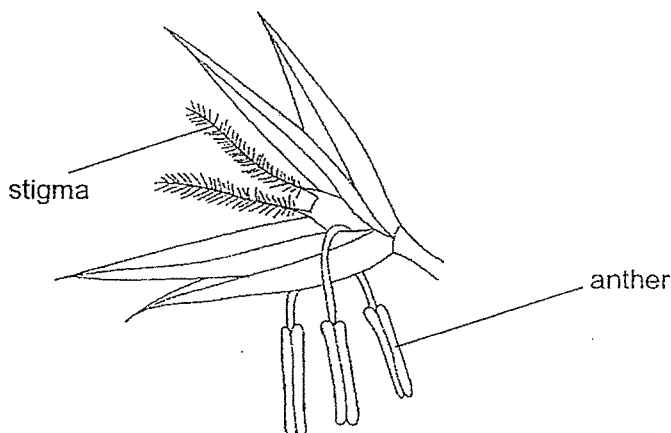

- State how the flower shown above is pollinated. [2]  
Explain your answer.

---

---

---

End of Term Review 2



YEAR : 2025  
 LEVEL : PRIMARY 6  
 SCHOOL : Henry Park PRIMARY SCHOOL  
 SUBJECT : SCIENCE  
 TERM : Term Review 2

**(BOOKLET A)**

Q1	3	Q2	2	Q3	4	Q4	1	Q5	3
Q6	2	Q7	3	Q8	1	Q9	1	Q10	4
Q11	3	Q12	4	Q13	2	Q14	2		

**(BOOKLET B)**

Q15	a)	Cytoplasm
	b)	H controls the movement of substances in and out of the cell.
	c)	The cell contains chloroplasts that is used by the leaf to take in light and make food to carry out photosynthesis.
	d)	The presence of the nucleus enables organism to grow a cap of a different shape. The nucleus controls the growth of a different cap.
Q16	a)	Red and blue light.
	b)	Fish found in Sections P and R as the water plants photosynthesize and give out oxygen for respiration.
	c)	The fishes will swim up to the surface. The air bubbles help the fish breathe. But since the water plants were removed, there was no air bubbles for the fish to breathe, thus swimming up to the surface to breathe as there was no oxygen.
Q17	a)	Absorb water from undigested food.
	b)	P
	c)	The small intestine digested all the food, and transported it into the bloodstream which leaves the undigested food going into the large intestine. No digestion taking place in the large intestine.
Q18	a)	Respiratory system.
	b)	C and B. Blood has to pass through the heart first as the heart pumps the blood to all parts of the body.
	c)	Contains more oxygen than the blood at H.
Q19	a)	When Organism C is placed in the light and dark, more carbon dioxide was present.
	b)	Photosynthesis. Photosynthesis can only take place when there is light around. During this process, gaseous exchange takes place, where carbon dioxide is taken in and oxygen is released. In the presence of light, D, a plant, took in carbon dioxide and give out oxygen. This increases the amount of oxygen turned the liquid A blue.

Q20	The anther is long and hangs outside the flower on a filament allowing pollen to be easily released when the wind blows. Stigma is large and feathery so it is able to catch the pollen grains easily.
-----	--